



Modular Cooking Range Line e-XP 700 Fryer 2x10 Liters OptiOil 800mm

ITEM # _____

MODEL # _____

NAME # _____

SIS # _____

AIA # _____



371222 (E7KKQTBAMEG)

e-XP OptiOil Fryer HP, 2x10-lit, electric, free standing, 2 wells (internal heating elements), 2 baskets and lid included

Short Form Specification

Item No. _____

The OptiOil Fryer is engineered for performance, efficiency, and ease of use and maintenance. A large digital display provides clear indication of temperature and operating status. All key components are front-accessible, and the well features rounded corners for easy cleaning. The unit's right-angled side edges allow flush alignment with adjacent equipment, preventing dirt accumulation. Constructed from AISI 304 stainless steel with Scotch Brite finish, it includes a one-piece 1.5 mm pressed worktop, height-adjustable stainless-steel feet, and IPX4 water protection. Oil drains through a front tap into a collection container beneath the well. The fryer features high-performance internal heating elements for fast heat transfer and stable temperature control up to 185 °C. Heating elements can be lifted for easy cleaning. Integrated oil filtration with a dedicated pump for each well, predisposed for an Advanced Filtering System with paper filters to extend oil life. Additional features include reduced-power fat-melting mode, standby function for energy savings, oil level alert, and manual-reset overtemperature protection. An optional oil quality monitoring tool (code 9B8081) supports precise oil management. The OptiOil Fryer is compliant with Swiss Energy Efficiency Ordinance (730.02) and designed to minimize oil consumption, ensuring reduced operating costs and consistent frying performance.

Main Features

- OptiOil Fryers are designed to optimize oil usage - compared to a traditional internal heating elements fryer - ensuring lower running costs.
- High Performance Internal Heating Elements engineered to provide rapid heat transfer and stable temperature control, ensuring fast preheating, high productivity and consistent frying conditions.
- AISI 304 heating elements located inside the well can be lifted up for easier cleaning.
- Large visible digital display showing temperature, on/off status of the appliance and on/off status of the heating elements.
- Oil Level Alert prompts the operator to refill oil, maintaining consistent frying performance.
- Reduced power setting to melt solid fat.
- Integrated oil filtering system with a pump for each well for oil circulation.
- The unit is predisposed for ADVANCED FILTERING SYSTEM with paper filters to remove the smallest food residuals and extend the oil life.
- All major compartments located in front of unit for ease of maintenance.
- Oil drains through a tap into a drainage container positioned under the well.
- Safety systems protect against overtemperature and can be manually reset.
- Electronic thermostatic regulation of oil temperature up to a maximum of 185 °C.
- Unit to be mounted on height adjustable feet in stainless steel.
- Optional portable oil quality monitoring tool (code 9B8081) for efficient oil management.
- Supplied as standard with 2 baskets and 2 doors.

Construction

- All exterior panels in Stainless Steel with Scotch Brite finishing.
- Model has right-angled side edges to allow flush fitting joints between units, eliminating gaps and possible dirt traps.
- One piece pressed 2 mm work top in Stainless steel.
- Interior of well with rounded corners for ease of cleaning.
- 2 separate wells for versatile frying.
- IPx4 water protection.

Sustainability

- This model is compliant with Swiss Energy Efficiency Ordinance (730.02).
- Standby function for energy saving and fast recovery of maximum power.



APPROVAL: _____



Experience the Excellence
www.electroluxprofessional.com

Included Accessories

- 2 of KIT FOR ADVANCED FILTRATION SYSTEM FOR OPTIOIL FRYERS - 700 LINE PNC 200029
- 2 of Stainless steel oil filter for OptiOil fryers PNC 200954
- 2 of Door for open base cupboard PNC 206350
- 2 of 1- FULL SIZE BASKET FOR 10LT OPTIOIL FRYERS PNC 921028

- 2 side covering panels, h=700mm, d=700mm PNC 216000
- 1- FULL SIZE BASKET FOR 10LT OPTIOIL FRYERS PNC 921028
- 2-HALF SIZE BASKETS FOR 10LT OPTIOIL FRYERS PNC 921029

Optional Accessories

- KIT FOR ADVANCED FILTRATION SYSTEM FOR OPTIOIL FRYERS - 700 LINE PNC 200029
- Pack of 100 paper filters for advanced filtration system for 23lt fryers with oil pump and OptiOil fryers PNC 200085
- Kit oil pump drain extension for 23lt fryers with oil pump and OptiOil fryers PNC 200087
- Stainless steel oil filter for OptiOil fryers PNC 200954
- Junction sealing kit PNC 206086
- 4 wheels, 2 swivelling with brake (700/900XP). It is mandatory to install with base supports for feet/wheels. PNC 206135
- Flanged feet kit PNC 206136
- Support for bridge type system, 1400mm PNC 206140
- Frontal kicking strip for concrete installation, 800mm PNC 206148
- Frontal kicking strip for concrete installation, 1000mm PNC 206150
- Frontal kicking strip for concrete installation, 1200mm PNC 206151
- Frontal kicking strip for concrete installation, 1600mm PNC 206152
- Frontal kicking strip, 800mm (not for refr-freezer base) PNC 206176
- Frontal kicking strip, 1000mm (not for refr-freezer base) PNC 206177
- Frontal kicking strip, 1200mm (not for refr-freezer base) PNC 206178
- Frontal kicking strip, 1600mm (not for refr-freezer base) PNC 206179
- 4 feet for concrete installation PNC 206210
- Pair of side kicking strips PNC 206249
- Pair of side kicking strips for concrete installation PNC 206265
- Chimney upstand, 800mm PNC 206304
- Right and left side handrails PNC 206307
- BACK HANDRAIL 800 MM - MARINE PNC 206308
- Door for open base cupboard PNC 206350
- Base support for feet or wheels - 800mm (700/900) PNC 206367
- Base support for feet or wheels - 1200mm (700/900) PNC 206368
- Base support for feet or wheels - 1600mm (700/900) PNC 206369
- Base support for feet or wheels - 2000mm (700/900) PNC 206370
- Rear paneling - 800mm (700/900) PNC 206374
- Rear paneling - 1000mm (700/900) PNC 206375
- Rear paneling - 1200mm (700/900) PNC 206376
- Chimney grid net, 400mm PNC 206400

Front

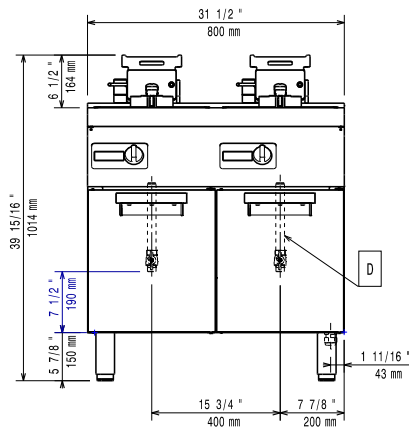

Side

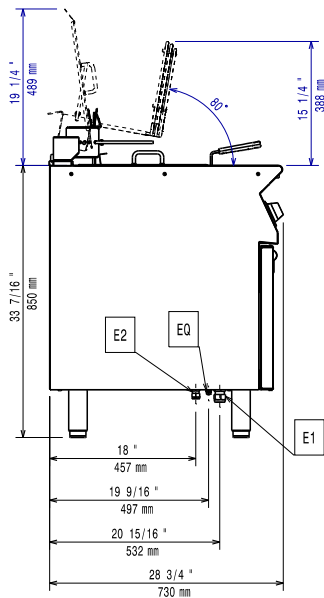

EI = Electrical inlet (power)
 EQ = Equipotential screw

Top

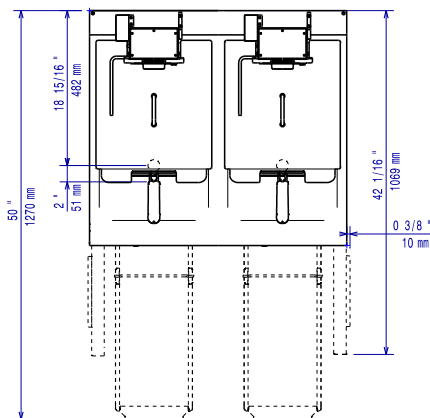

Electric

Supply voltage: 380-415 V/3N ph/50-60 Hz
 Total Watts: 24 kW

Key Information:

Usable well dimensions (width): 240 mm
 Usable well dimensions (height): 203 mm
 Usable well dimensions (depth): 380 mm
 Well capacity: 9 lt MIN; 12 lt MAX
 Thermostat Range: 100 °C MIN; 185 °C MAX
 External dimensions, Width: 800 mm
 External dimensions, Depth: 730 mm
 External dimensions, Height: 850 mm
 Net weight: 83 kg
 Shipping weight: 104 kg
 Shipping height: 1230 mm
 Shipping width: 840 mm
 Shipping depth: 900 mm
 Shipping volume: 0.93 m³
 Certification group: eXPEFI7210